

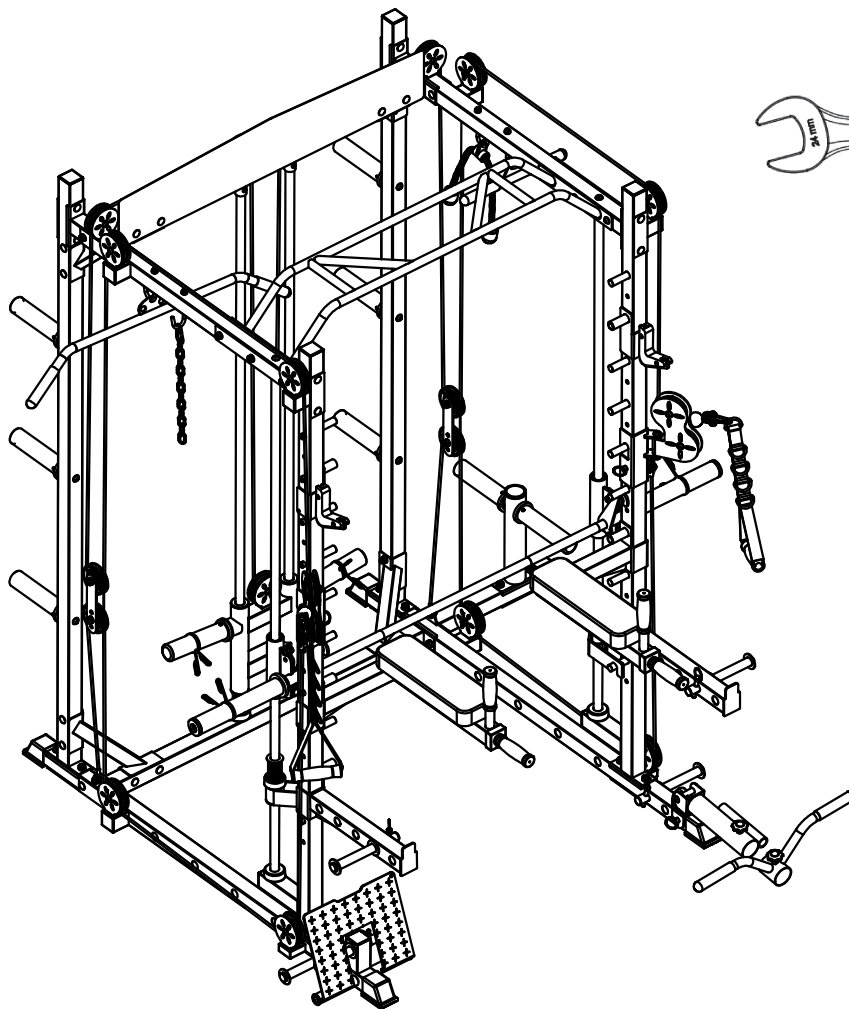

MIKOLO

ASSEMBLY INSTRUCTIONS

ZL-M3



2x NOT INCLUDED

NOTE: DO NOT FULLY
TIGHTEN HARDWARE
UNTIL FINAL STEP



MIKOLOGYM

MIKOLO RECOMMENDS TWO PEOPLE
NEEDED TO ASSEMBLE THIS CAGE I
N FLAT GROUND.

MEET ANY QUESTION ASSEMBLING OR PRODUCT?

EMAIL US FOR CUSTOMER SERVICE

after-sale@gym-mikolo.com

www.gym-mikolo.com

Read all precautions and instructions in this manual before using this equipment

Assembly Caution	-----	3
Part List A	-----	4
Part List B	-----	5
Part List C	-----	6
Step 1	-----	7
Step 2	-----	8
Step 3	-----	9
Step 4	-----	10
Step 5	-----	11
Step 6	-----	12
Step 7	-----	13
Step 8	-----	14
Step 9	-----	15
Step 10	-----	16
Step 11	-----	17

ASSEMBLY CAUTION





Make Things Easier for Yourself

Everything in this manual is designed to ensure that the weight system can be assembled successfully by anyone. However, it is important to realize that the versatile weight system has many parts and that the assembly process will take time. Most people find that by setting aside plenty of time, assembly will go smoothly.

Before beginning assembly, carefully read the following information and instructions:





- Assembly requires two people.
- Place all parts in a cleared area and remove the packing materials. Do not dispose of the packing materials until assembly is completed.
- Tighten all parts as you assemble them, unless instructed to do otherwise.
- As you assemble the weight system, make sure all parts are oriented as shown in the drawings.
- ***For help identifying small parts, refer to the PARTS LIST A B C***

The following tools (not included) are required for assembly:



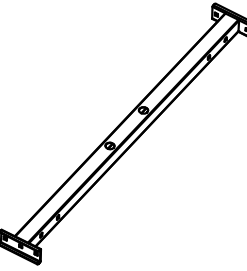
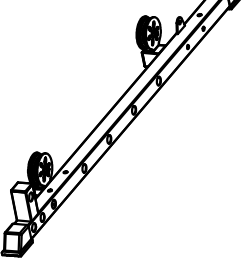
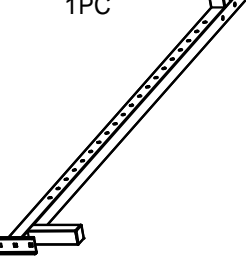
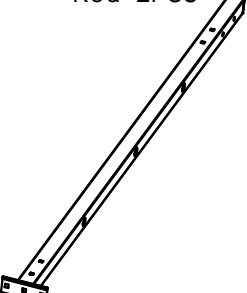
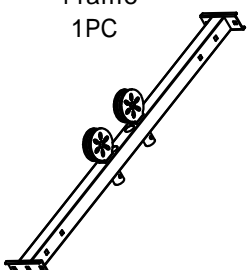
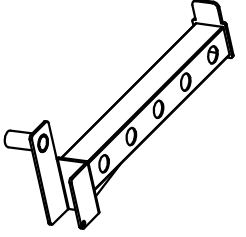
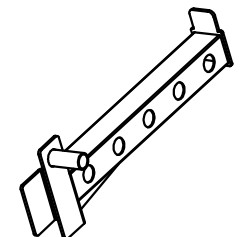

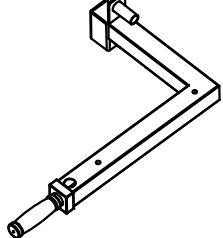
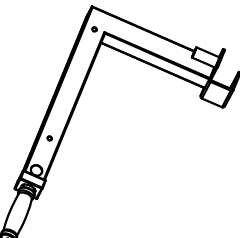
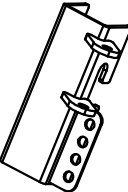
- Two adjustable wrenches 
- One rubber mallet 
- One standard screwdriver 
- One Phillips screwdriver 
- Lubricant, such as grease or petroleum jelly, and soapy water.

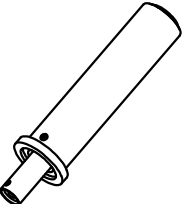
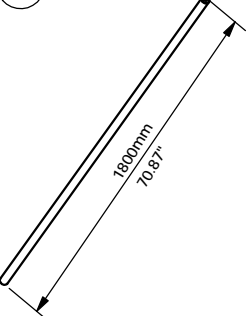
Assembly will be more convenient if you have a socket set, a set of open-end or closed-end wrenches, or a set of ratchet wrenches.



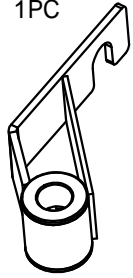
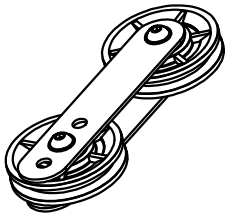
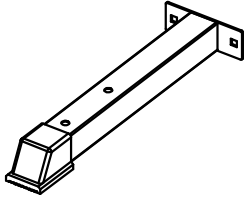
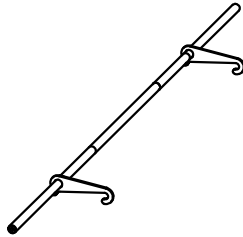
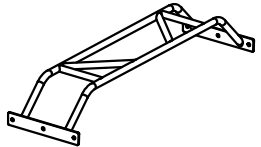
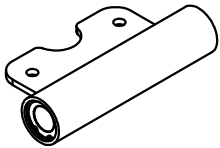
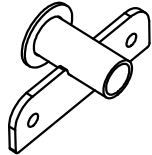
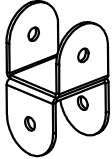
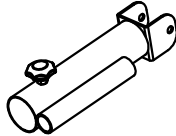
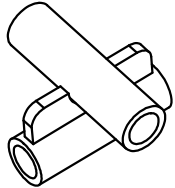
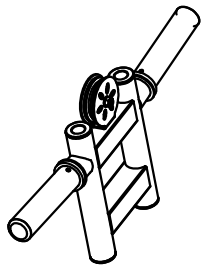
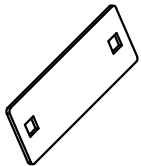
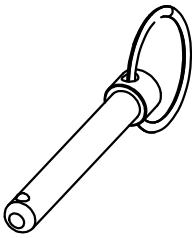
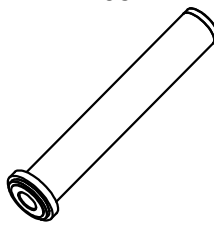
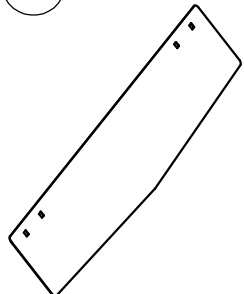
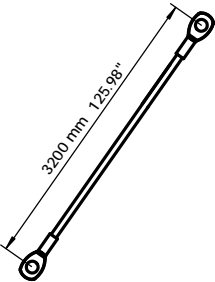
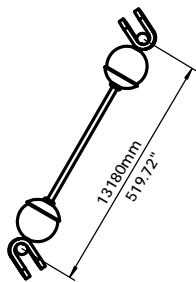
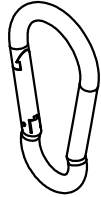
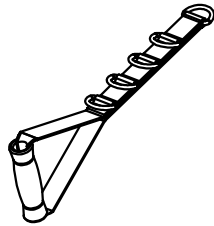

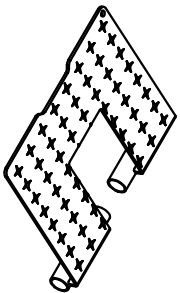
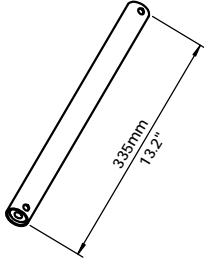

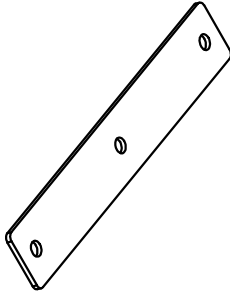
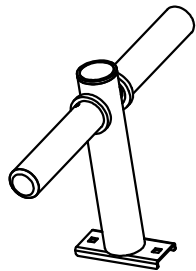

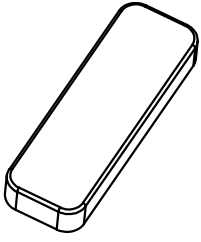
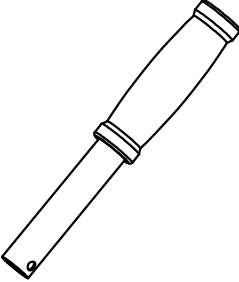
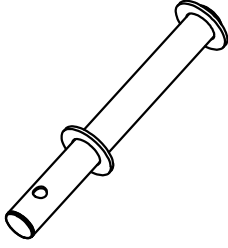
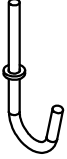
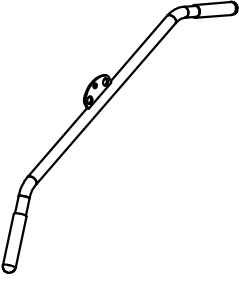
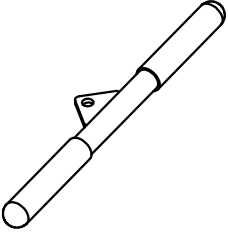
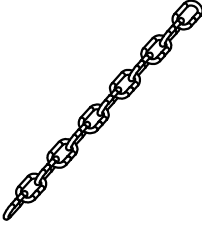
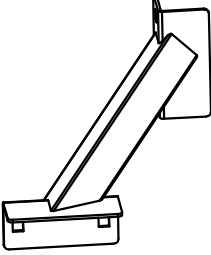
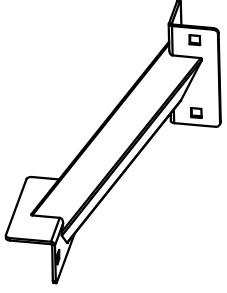
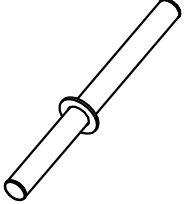

PARTS LIST A

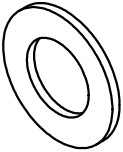
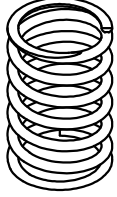
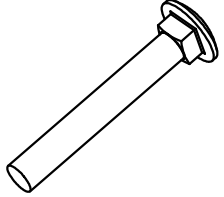
<p>A1 Guide Rod Base 1PC</p> 	<p>A2 Left Base 1PC</p> 	<p>A3 Right Base 1PC</p> 	<p>A4 Middle Upright Left Rod 1PC</p> 	<p>A5 Middle Upright Right Rod 1PC</p> 
<p>A6 Rear Upright Rod 2PCS</p> 	<p>A7 Rear Cross Frame 1PC</p> 	<p>A8 Smith Bar Catch Peg 20PCS</p> 	<p>A9 Safety Bar Left 1PC</p> 	<p>A10 Safety Bar Right 1PC</p> 
<p>B1 Upper Left Frame 1PC</p> 	<p>B2 Upper Right Frame 1PC</p> 	<p>B3 J Hook Left 1PC</p> 	<p>B4 J Hook Right 1PC</p> 	<p>B5 Smith Bar Tube 2PCS</p> 
<p>B6 Shockpad 6PCS</p> 	<p>B7 Dip Bar Left 1PC</p> 	<p>B8 Dip Bar Right 1PC</p> 	<p>B9 Sliding Sleeve Left 1PC</p> 	<p>B10 Sliding Sleeve Right 1PC</p> 
<p>C1 Sliding Pulley 2PCS</p> 	<p>C2 Weight Storage Pin Sleeve 6PCS</p> 	<p>C3 Guide Rod 2PCS</p> 	<p>C4 T-Bar 1PC</p> 	<p>C5 Smith Bar Catch Left 1PC</p> 

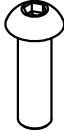
PARTS LIST B

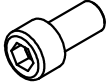
<p>C6 Smith Bar Catch Right 1PC</p> 	<p>C7 Moving Pulley 2PCS</p> 	<p>C8 Storage Base 1PC</p> 	<p>C9 Smith Bar 1PC</p> 	<p>C10 Pull-Up Frame 1PC</p> 
<p>D1 Smith Bar Bearing Tube 2PCS</p> 	<p>D2 Smith Bar Fixed Tube 2PCS</p> 	<p>D3 Landmine Base 1PC</p> 	<p>D4 Landmine 1PC</p> 	<p>D5 360 ° Landmine Connection 1PC</p> 
<p>D6 Weight Holder 1PC</p> 	<p>D7 110 Connecting Piece 12PCS</p> 	<p>D8 Latch 7PCS</p> 	<p>D9 Smith Bar Catch Peg 2PCS</p> 	<p>D10 LOGO Board 1PC</p> 
<p>E1 Cable 3200mm 2PCS</p>  <p>3200 mm 125.98"</p>	<p>E2 Cable 13300mm 1PC</p>  <p>13180mm 519.72"</p>	<p>E3 Clip 3PCS</p> 	<p>E4 Cable Handle 2PCS</p> 	<p>E5 50 Spring Clip 4PCS</p> 
<p>E6 Foot Pedal 1PC</p> 	<p>E7 Foot Pedal Connecting Column 1PC</p>  <p>335mm 13.2"</p>	<p>E8 Foot Pedal Washer 2PCS</p> 	<p>E9 Connecting Piece 2PCS</p> 	<p>E10 Weight Storage Rack 1PC</p> 

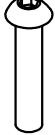
PARTS LIST C

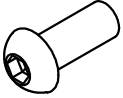
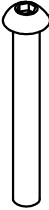
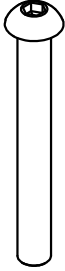
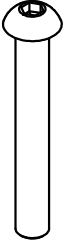
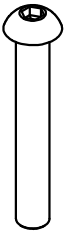
<p>F1 Tricep Rope 1PC</p> 	<p>F2 Forearm Pad 2PCS</p> 	<p>F3 Grip Handle 2PCS</p> 	<p>F4 Band Peg 4PCS</p> 	<p>F5 Hook 4PCS</p> 
<p>F6 Lat Pull Down Bar 1PC</p> 	<p>F7 Cable Bar 1PC</p> 	<p>F8 Chain 1PC</p> 	<p>F9 Diagonal Tube A 2PCS</p> 	<p>F10 Diagonal Tube B 2PCS</p> 
<p>G1 Foot Pedal Support Column 1PC</p> 	<p>G2 25 Spring Clip 1PC</p> 	<p>G3 Baffle 8PCS</p> 	<p>G4 Spring 4PCS</p> 	<p>G5 M10*70 Bolt 42PCS</p> 
<p>G6 M10 Washer 84PCS</p> 	<p>G8 M10*20 Bolt 14PCS</p> 	<p>G10 M10*30 Bolt 2PCS</p> 	<p>H2 M8 Washer 8PCS</p> 	<p>H4 M10*20 Bolt 20PCS</p> 
<p>G7 M10 Nut 62PCS</p> 	<p>G9 M10*25 Bolt 4PCS</p> 	<p>H1 M8*40 Bolt 2PCS</p> 	<p>H3 M8 Nut 6PCS</p> 	<p>H5 M12*30 Bolt 2PCS</p> 
<p>H6 M8*65 Bolt 4PCS</p> 	<p>H7 M10*85 Bolt 2PCS</p> 	<p>H8 M10*75 Bolt 1PCS</p> 	<p>H9 M10*70 Bolt 9PCS</p> 	

STEP: 1

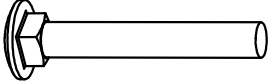
G5  M10*70 Bolt 14PCS

G6  M10 Washer 4PCS

G7  M10 Nut 4PCS

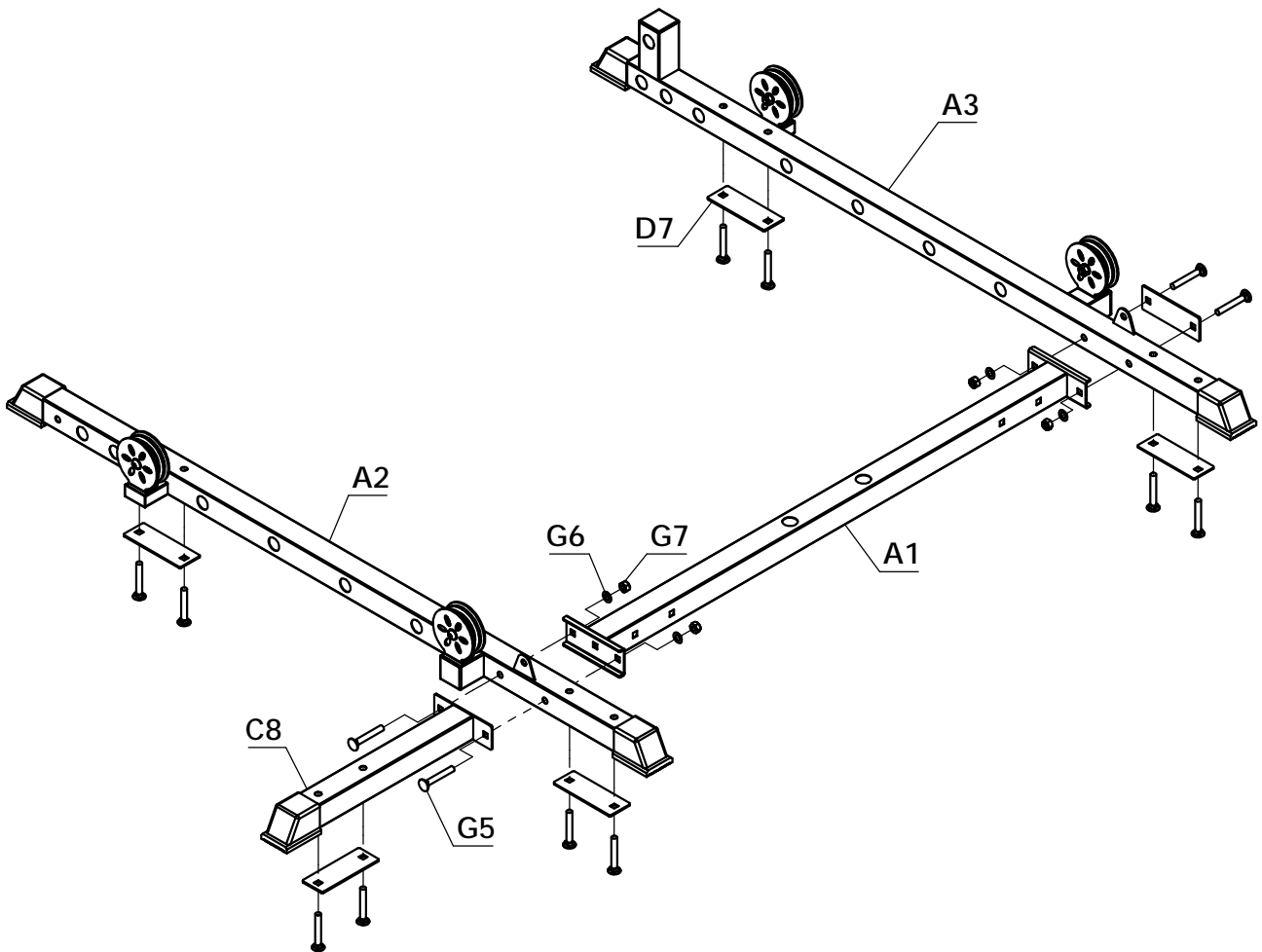

1. Preset G5 under A2 through D7;
2. Preset G5 under A3 through D7;
3. Preset G5 under C8 through D7;
4. Connect G5 and D7 to lock A1, A2, A3 and C8 with G6 and G7.

STEP: 2

G6



M10 Washer 8PCS

G7



M10 Nut 8PCS

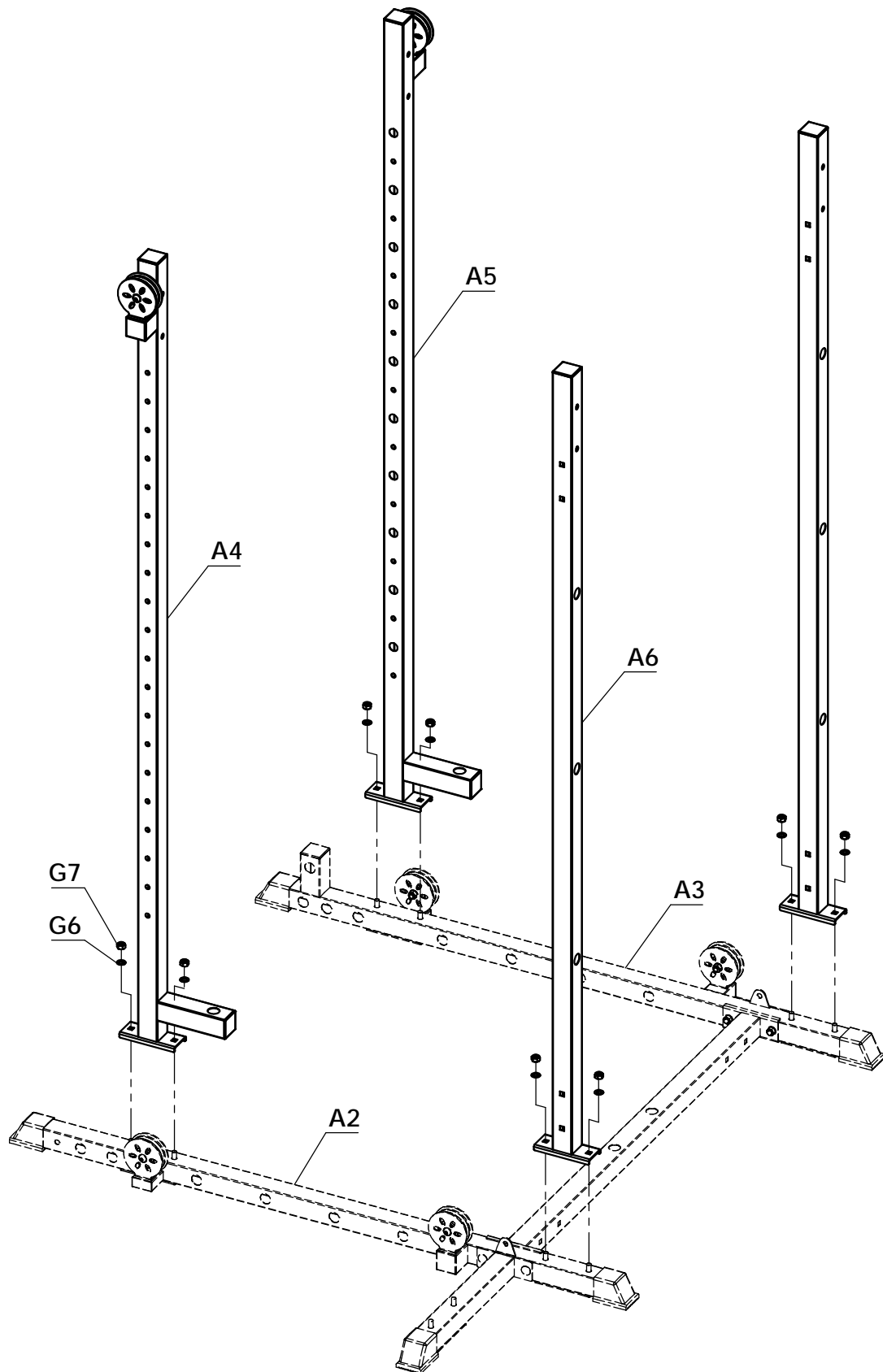

1. Connect A4, A5 and A6 with G6 and G7 and the previously preset bolts on A2 and A3.

STEP: 3

G5  M10*70 Bolt 12PCS
 H9  M10*70 Bolt 6PCS

G6  M10 Washer 24PCS

G7  M10 Nut 18PCS

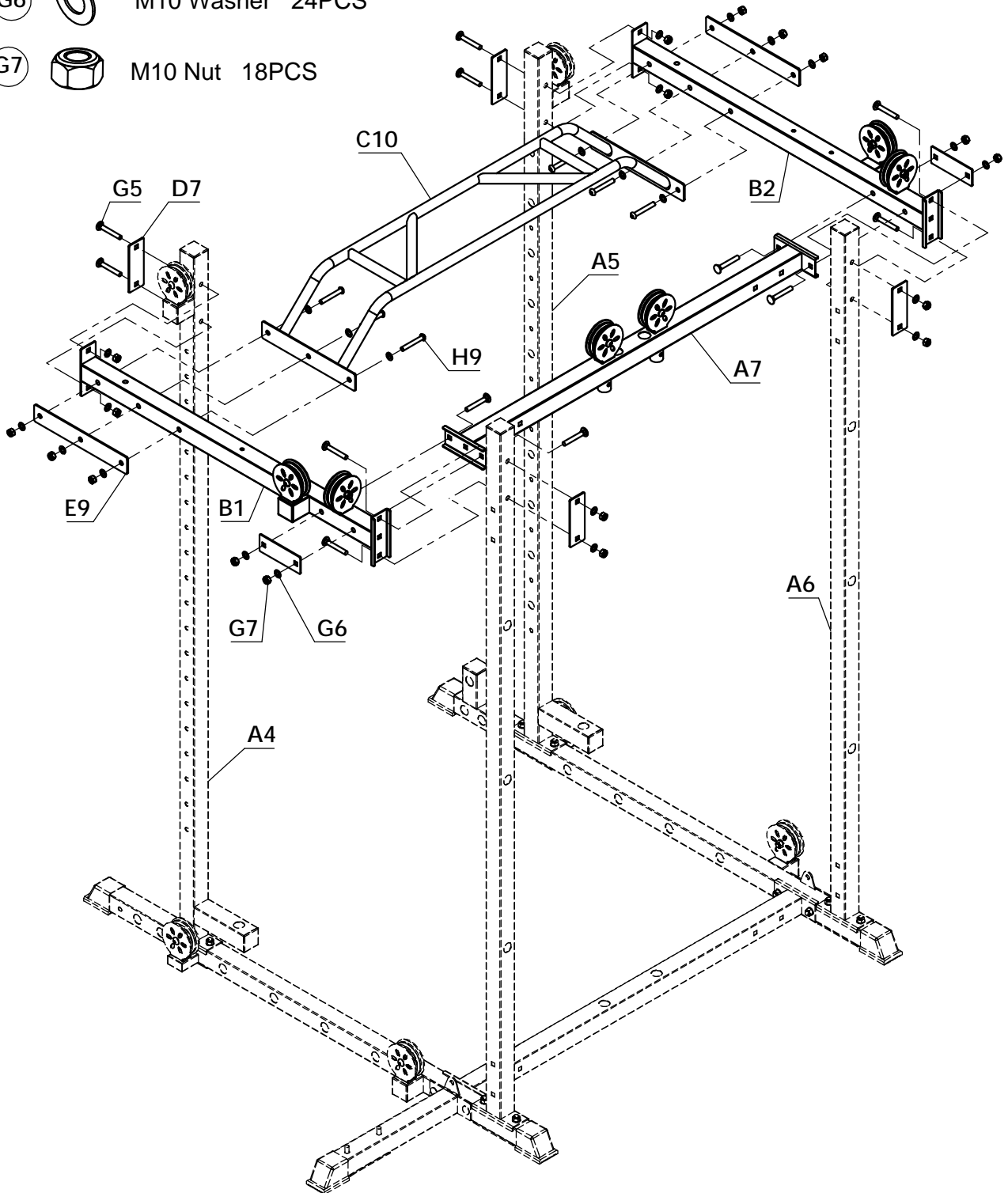

1. G5 connects A4, A6 and B1 with G6 and G7 through D7;
2. Connect A5, A6 and B2 with G6 and G7 through G5 and D7;
3. G5 connects A7, B1 and B2 with G6 and G7 through D7;
4. Connect B1, B2 and C10 with G6 and G7 through H9 and E9.

STEP: 4

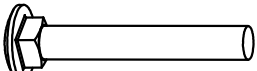
G5  M10*70 Bolt 16PCS

G6  M10 Washer 16PCS

G7  M10 Nut 16PCS

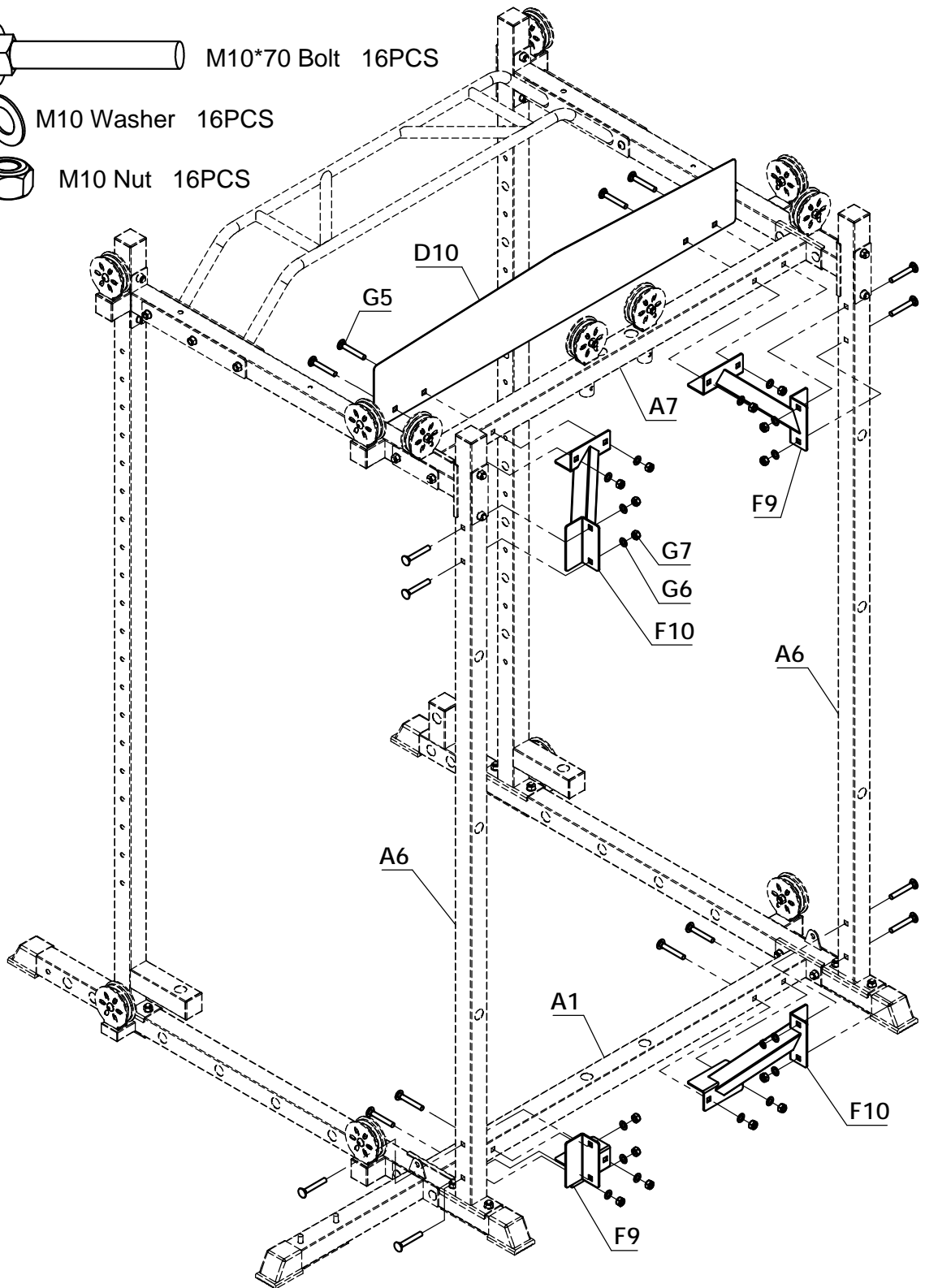

1. Connect G5 with A6, A7 and F9 with G6 and G7 through D10;
2. Connect A6, A7 and F10 with G6 and G7 through D10;
3. Connect A6 and F9 with G5, G6 and G7;
4. Connect A6 and F10 with G5, G6 and G7;
5. Connect A1, A6 and F9 with G5, G6 and G7;
6. Connect A1, A6 and F10 with G5, G6 and G7;
7. Lock the screws in the above steps.

STEP: 5

G8  M10*20 Bolt 6PCS

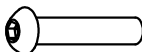
H1  M8*40 Bolt 2PCS

G6  M10 Washer 6PCS



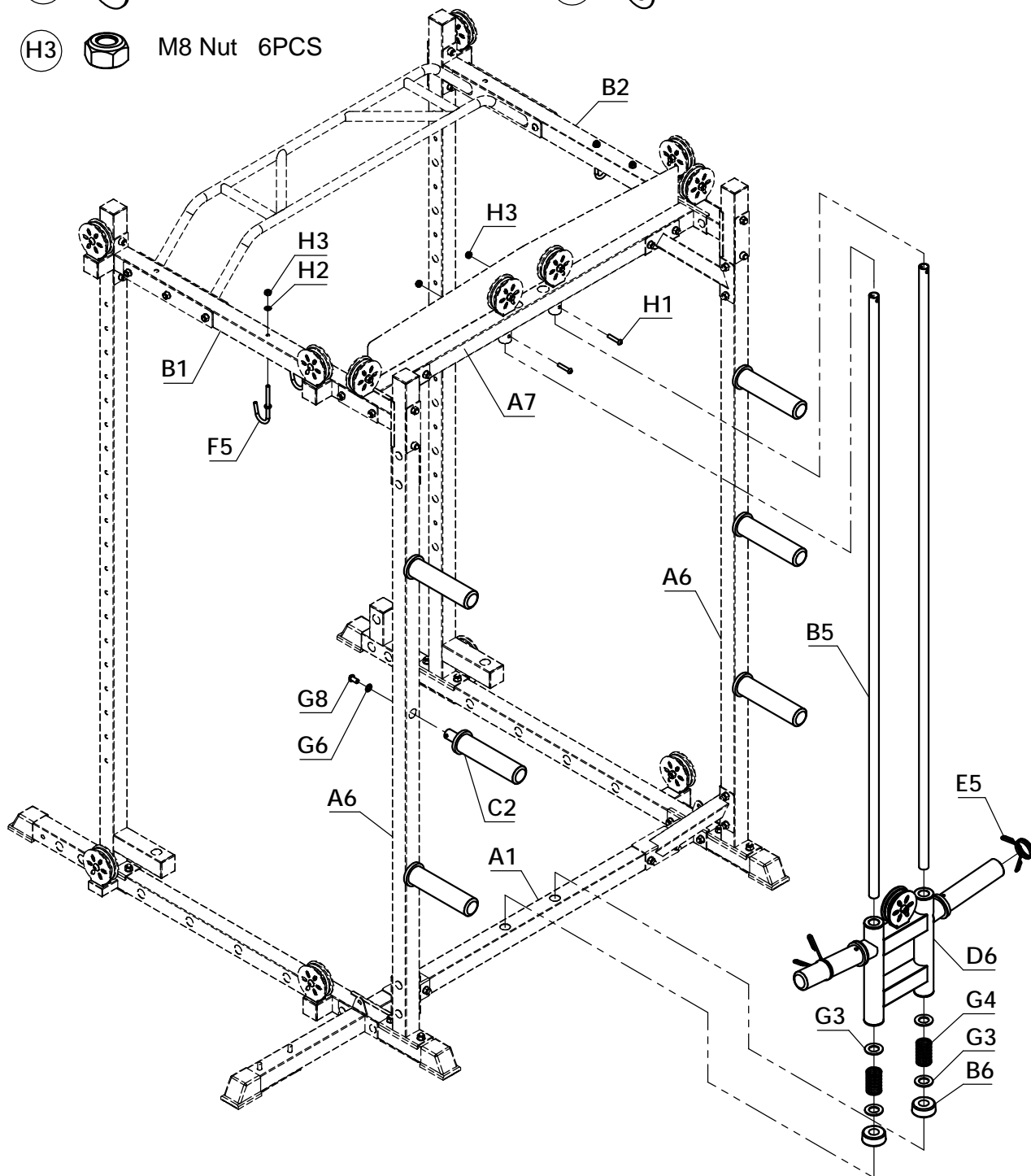

H2  M8 Washer 4PCS

H3  M8 Nut 6PCS

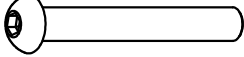
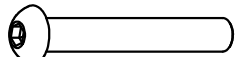

1. Connect and lock C2 with G6, G8 and A6;
2. Connect F5 with B1 and B2 with H2 and H3 respectively and keep F5 rotating;
3. Put the end of B5 with a small hole upward, the lower end through D6, G3, G4, G3 and B6, and finally insert it into the hole of A1, and the upper end into the sleeve of A7, and lock it with H1 and H3 connections;
4. Clip E5 onto D6.

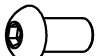
STEP: 6

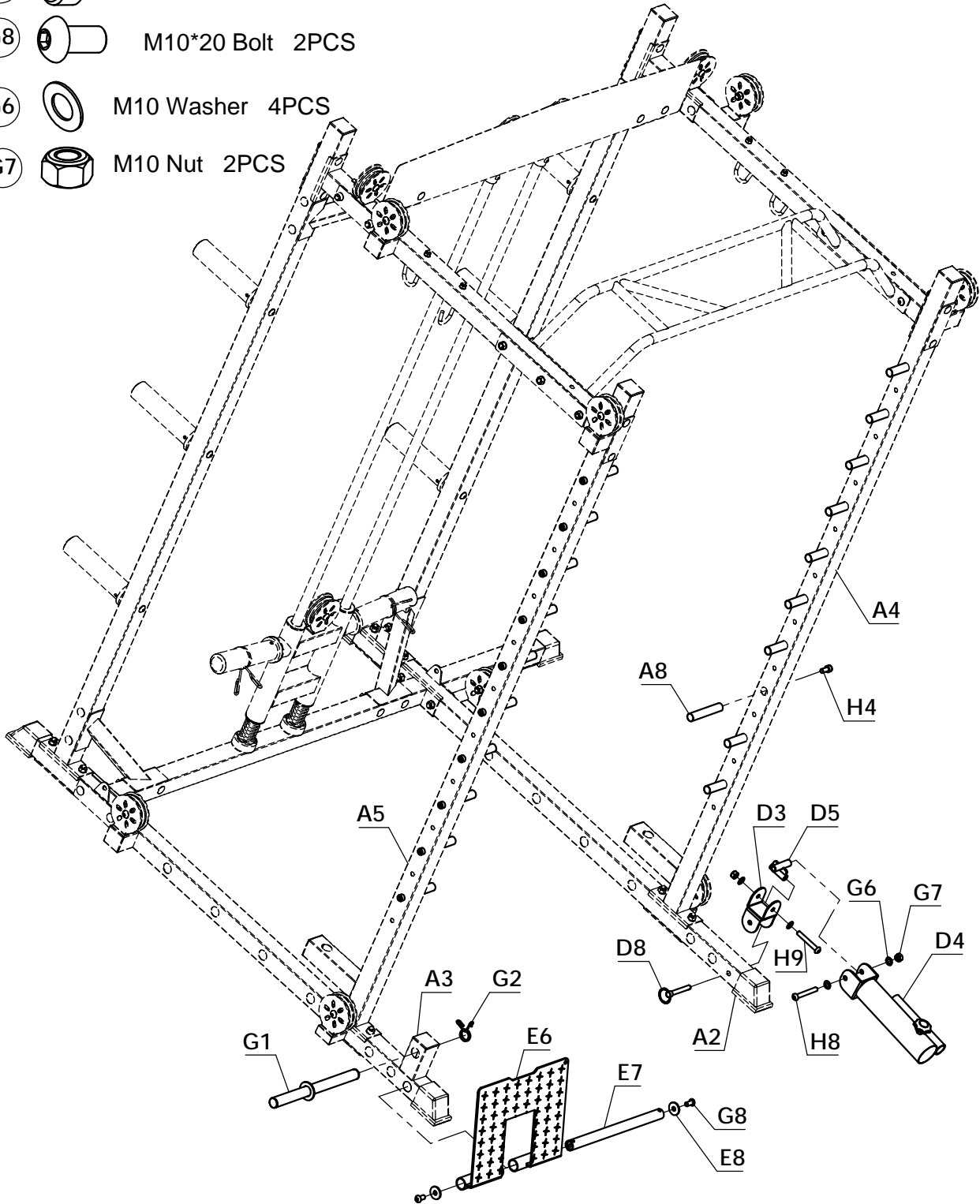

- (H8)  M10*75 Bolt 1PCS (H9)  M10*70 Bolt 1PCS
- (H4)  M10*20 Bolt 20PCS
- (G8)  M10*20 Bolt 2PCS
- (G6)  M10 Washer 4PCS
- (G7)  M10 Nut 2PCS



1. Connect D3 and A2 with D8;
2. Connect D3 and D5 with G6, G7 and H9, and D5 can still rotate flexibly when G7 is locked;
3. Connect D4 and D5 with G6, G7 and H8, and D4 can still rotate flexibly when G7 is locked;
4. Insert G1 into A3 and clamp it with G2;
5. Connect A3 and E6 with E7, and lock both ends with E8 and G8;
6. Connect and lock A8 with A4 and A5 respectively with H4.

STEP: 7

(H9)  M10*70 Bolt 2PCS

(G6)  M10 Washer 4PCS (G7)  M10 Nut 2PCS

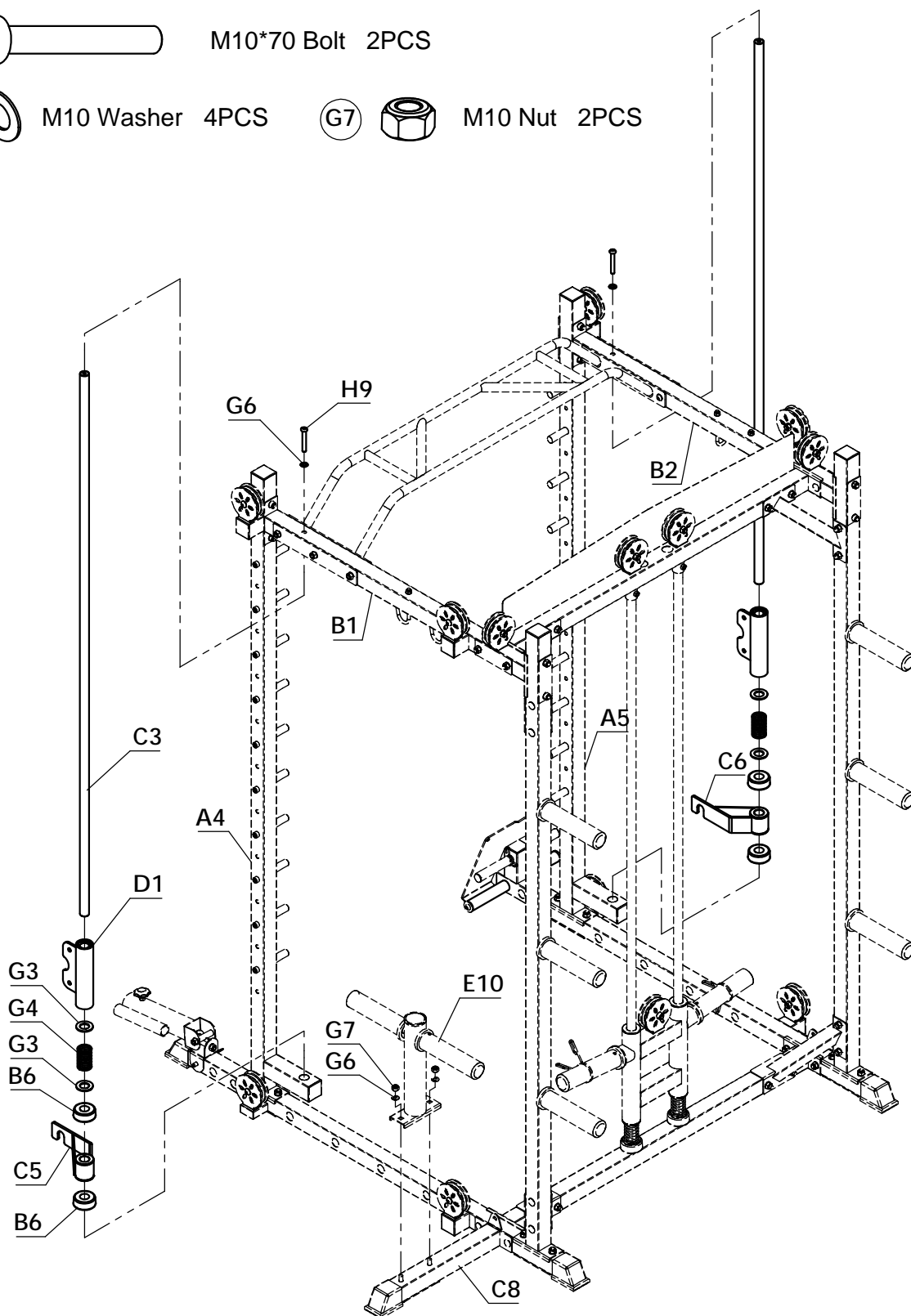

1. The end of C3 wire hole is upward, and the lower end is inserted into the hole of A4 through D1, G3, G4, G3, B6, C5 and B6 successively, and the upper end is connected and locked with B1 by G6 and H9;
2. The end of C3 wire hole is upward, the lower end is inserted into the hole of A5 through D1, G3, G4, G3, B6, C6 and B6 in turn, and the upper end is connected and locked with G6, H9 and B2;
3. Connect and lock the preset bolts on E10 and C8 with G6 and G7.

STEP: 8

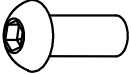
(H5)  M12*30 Bolt 2PCS

(H7)  M10*85 Bolt 2PCS

(G6)  M10 Washer 12PCS

(G7)  M10 Nut 6PCS

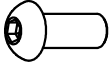
(G9)  M10*25 Bolt 4PCS

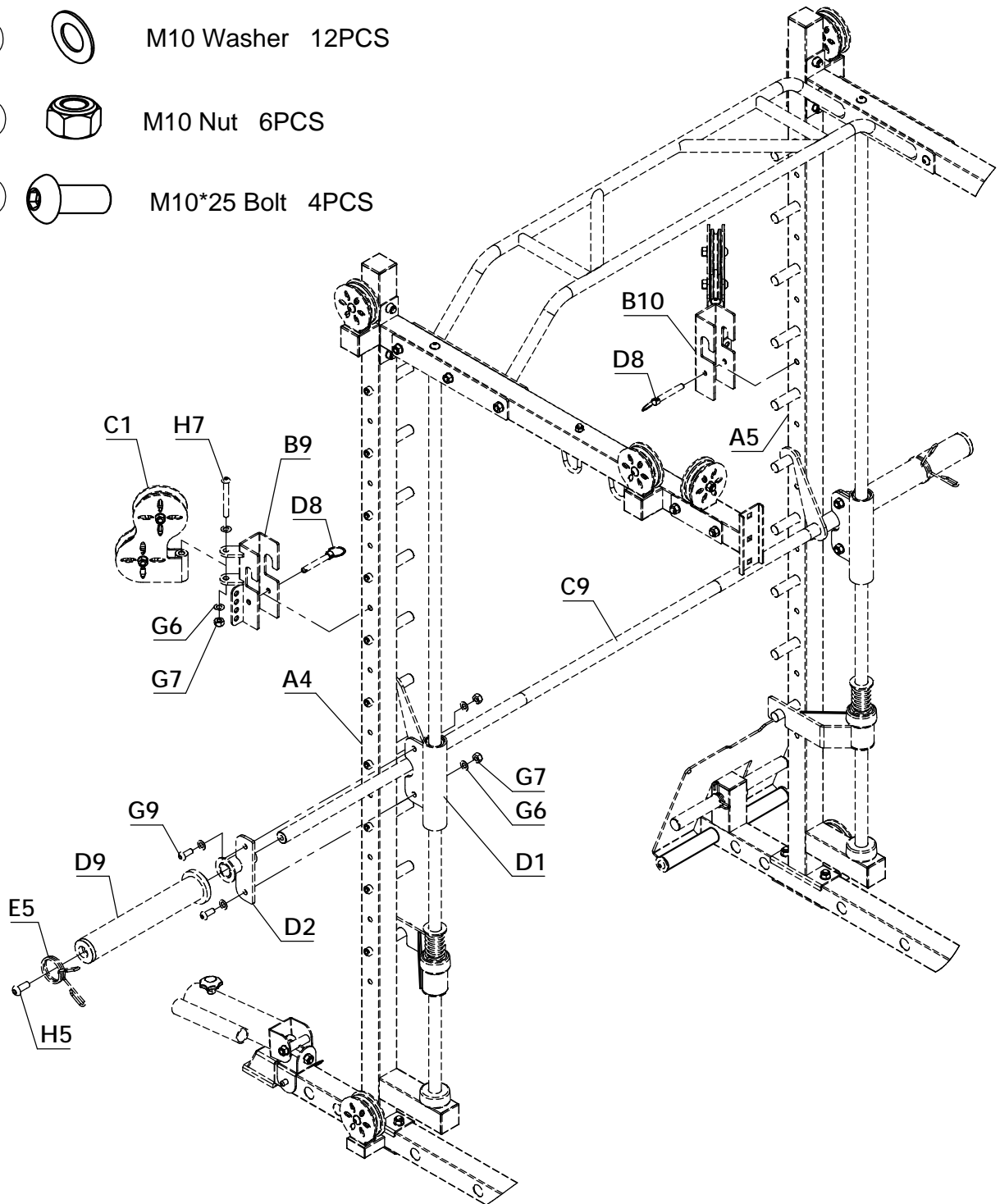

1. Put D2 on both ends of C9, and use G6, G7 and G9 to lock D2 and D1;
2. Insert D9 into both ends of C9 and lock it with H5 connection;
3. Card E5 onto D9;
4. Use D8 to clamp B9 onto A4;
5. Use D8 to clamp B10 onto A5;
6. Connect C1 and B9 with G6, G7 and H7, and C1 can still rotate flexibly when G7 is locked;
7. Connect C1 and B10 with G6, G7 and H7. When G7 is locked, C1 can still rotate flexibly.

STEP: 9

G7  M10 Nut 2PCS

G10  M10*30 Bolt 2PCS

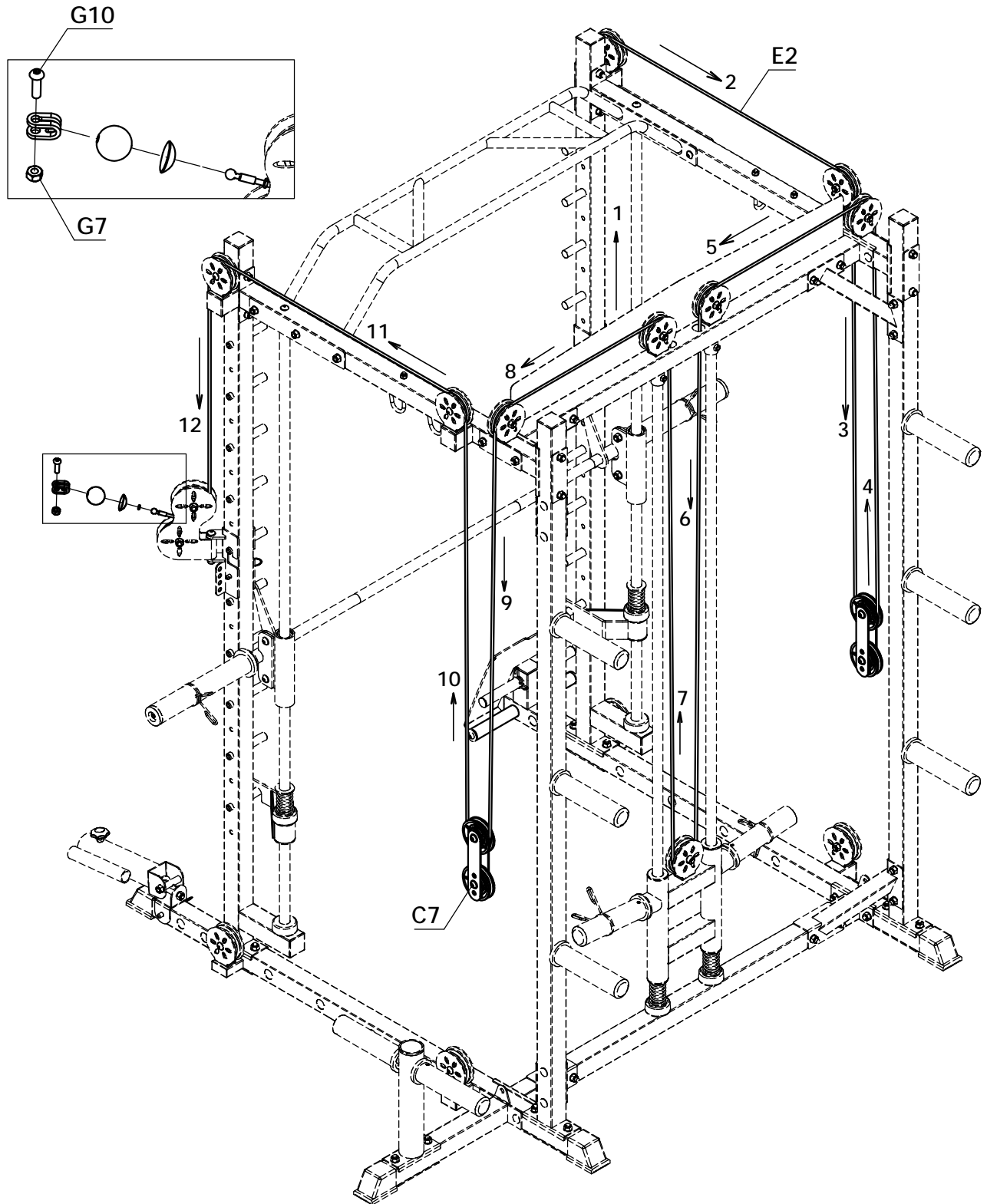

1. Take down the accessories at one end of E2, penetrate the cables in sequence according to the direction of the cables, place the cables in the pulley groove, and finally install the accessories back;
2. Thread G10 into the U-shaped clamp hole of E2 accessory, and screw on G7.

STEP: 10

G8  M10*20 Bolt 4PCS

G7  M10 Nut 4PCS

G6  M10 Washer 4PCS

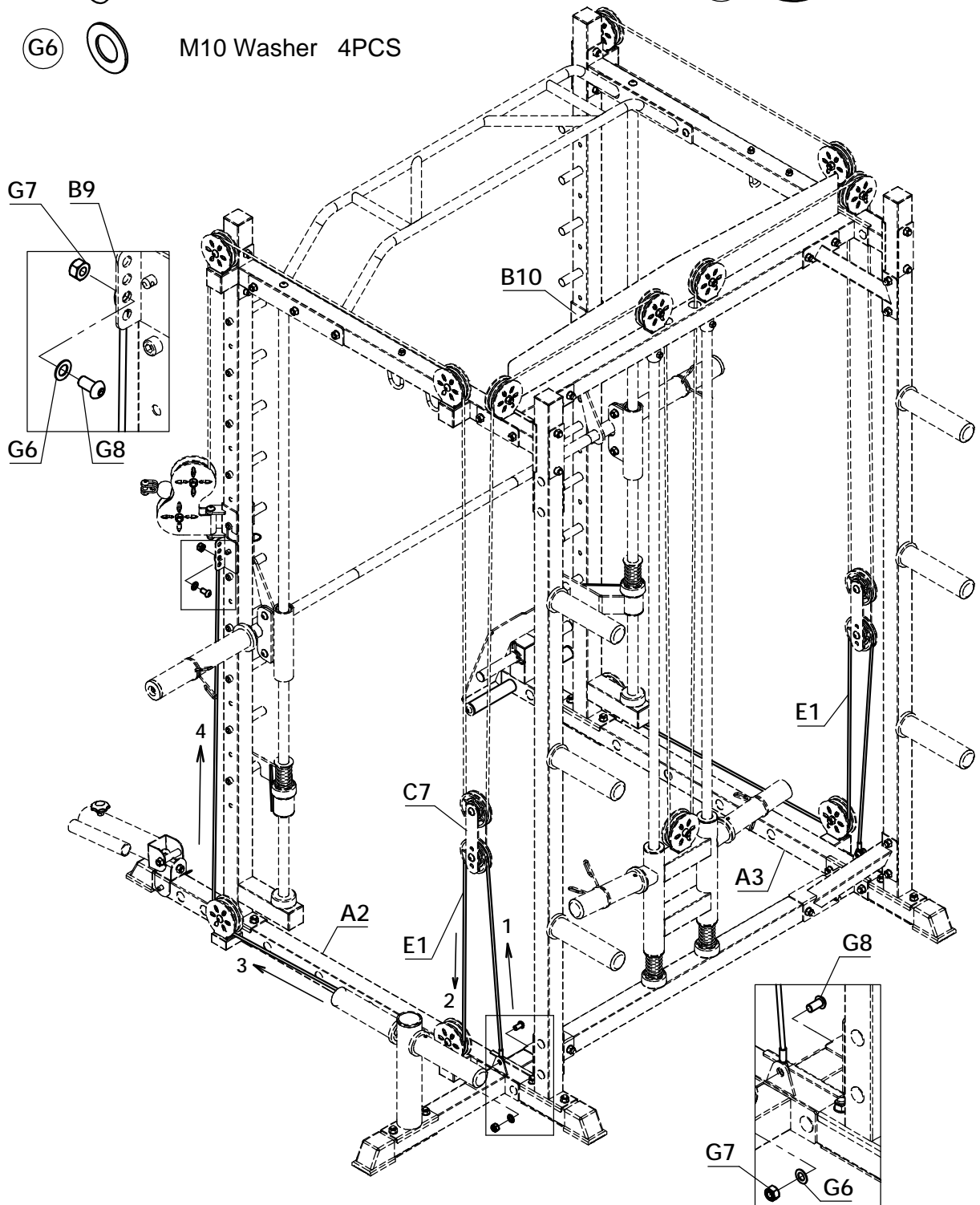

1. Fix one end of E1 to the triangle of A2 with G6, G7 and G8 and lock it;
2. According to the direction of the wire rope (if necessary, remove the pre-installed pulley, put the wire rope in the pulley groove and then install it back), and finally fix the wire rope on the adjusting plate of B9 with G6, G7 and G8;
3. Fasten one end of E1 to the triangle of A3 with G6, G7 and G8;
4. According to the direction of the wire rope (if necessary, take down the pre-installed pulley, put the wire rope in the pulley groove and then install it back), and finally fix the wire rope on the adjusting plate of B10 with G6, G7 and G8.

STEP:11

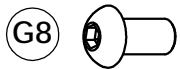

M10*20 Bolt 2PCS



M8*65 Bolt 4PCS



M10 Washer 2PCS



M8 Washer 4PCS

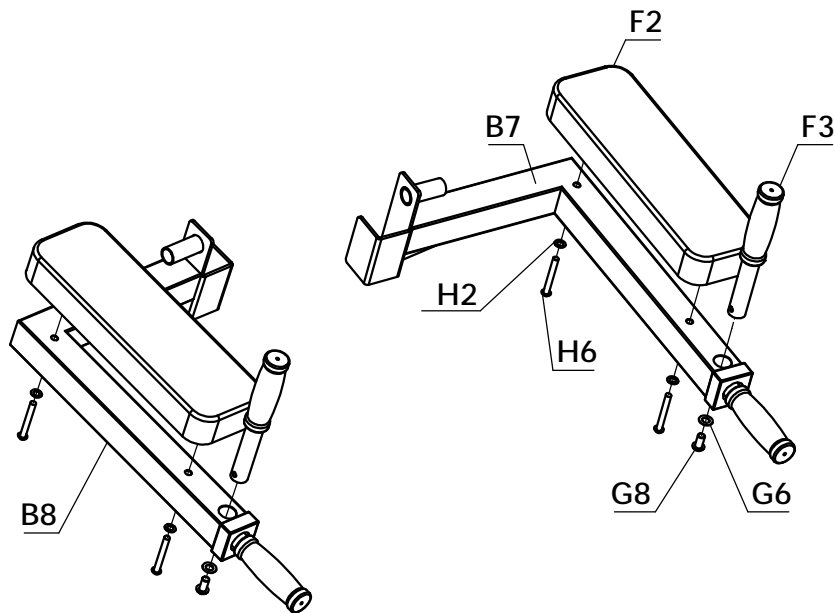

1. Lock F2 and B7 with H2 and H6;
2. Lock F2 and B8 with H2 and H6;
3. Use G6 and G8 to lock F3 and B7;
4. Use G6 and G8 to lock F3 and B8.

At this point, the installation is complete. Before use, check the fastening of the screw and whether the wire rope is in the groove of the pulley. Other accessories, such as A9, A10, B3 and B4, can be used according to the needs of exercise. Thank you for your patronage and welcome again.